



New Brunswick -86 °C Freezers Innova®

Operating manual
M1288-0052
Revision T



Copyright

Copyright© 2011 New Brunswick Scientific Co., Inc., USA. No part of this publication may be reproduced without the prior permission of the copyright owner.

New Brunswick Scientific reserves the right to change information in this document without notice. Updates to information in this document reflect our commitment to continuing product development and improvement.

Trademarks

Eppendorf® is a registered trademark of Eppendorf AG, Germany.

BioCommand® is a registered trademark of New Brunswick Scientific Co., Inc., USA.

Innova® is a registered trademark of New Brunswick Scientific Co., Inc., USA.

New Brunswick™ and the New Brunswick Logo™ are trademarks of Eppendorf AG, Germany.

S.M.A.R.T. Plus™ is a pending trademark of New Brunswick Scientific Co., Inc., USA.

Trademarks are not marked in all cases with ™ or ® in this manual.

New Brunswick Scientific has attempted to identify the ownership of all trademarks from public records. Any omissions or errors are unintentional.

Table of contents

- 1 Operating instructions 5**
 - 1.1 Using this manual 5
 - 1.2 Danger symbols and danger levels 5
 - 1.2.1 Hazard symbols 5
 - 1.2.2 Degrees of danger 5
 - 1.3 Symbols used 5
 - 1.4 Abbreviations used 6
- 2 Safety 7**
 - 2.1 Intended use 7
 - 2.2 Warnings for intended use 7
 - 2.2.1 Manual conventions used 7
 - 2.2.2 Health and safety at work act 1974 7
- 3 Product description 8**
 - 3.1 Main illustration 8
 - 3.2 Delivery package 10
 - 3.2.1 Inspection of boxes 10
 - 3.2.2 Packing list verification 10
 - 3.3 Product versions 10
 - 3.3.1 Introduction 10
 - 3.4 Features 11
 - 3.5 Warranty 12
 - 3.5.1 Warranty registration 12
 - 3.5.2 Extended warranty option 12
- 4 Installation 13**
 - 4.1 Preparing installation 13
 - 4.2 Selecting the location 13
 - 4.3 Installing the shelves 13
 - 4.4 Lockable freezer handle 13
- 5 Operating controls and function 15**
 - 5.1 Controls and function 15
- 6 Operation 19**
 - 6.1 Getting started 19
 - 6.1.1 Plug in 19
 - 6.1.2 Turning the freezer On/Off 19
 - 6.1.3 Alarm/battery activation 20
 - 6.1.4 Testing the alarm monitoring socket 21
 - 6.1.5 Vacuum Effect 21
 - 6.2 Programming the freezer 21
 - 6.2.1 Setting operating temperature 21
 - 6.2.2 Setting high alarm setpoint 22
 - 6.2.3 Setting low alarm setpoint 22
 - 6.2.4 Checking temperature and alarm setpoint settings 23
 - 6.2.5 Setting the alarm delay 23
 - 6.2.6 Changing lock codes 24
 - 6.2.7 Setting the temperature offset 24
 - 6.3 Battery backup switch 24

6.4	Alarm monitoring socket	25
6.5	Voltage stabilizer	26
7	Maintenance	28
7.1	Cleaning	28
7.1.1	Painted surfaces	28
7.1.2	Panels and shelves	28
7.1.3	Air intake grille and filter	28
7.1.4	Heated vent port	28
7.1.5	Door or lid seal	29
7.2	Routine maintenance	29
7.2.1	Lubrication	29
7.2.2	Defrosting	29
7.2.3	Removing the inner doors	29
7.2.4	Replacing the inner door	30
7.2.5	Electrical components	30
8	Troubleshooting	32
8.1	General errors	32
8.2	Error messages	32
8.3	After a mains/power failure	33
8.4	Interior warming	33
9	Technical data	34
9.1	Specifications	34
9.1.1	Upright freezers specifications	34
9.1.2	Chest freezers specifications	35
10	Ordering Information	36
10.1	Accessories	36
10.1.1	A2 independent temperature monitor	36
10.1.2	Auto-dialers	36
10.1.3	Temperature probes	36
10.1.4	Validation packages	36
10.1.5	External voltage stabilizers	36
10.1.6	Padlock adapter kits	36
10.1.7	CO ₂ and LN ₂ back-up systems	36
10.1.8	Inventory racking systems	36
10.1.9	Chart recorder	36
10.1.10	New Brunswick BioCommand SFI datalogging software (RS-485 interface)	37
11	Transport, storage and disposal	38
11.1	Shut down	38
11.2	Transport	38
11.3	Disposal	38
12	Certificates	39
	Index	40





1 Operating instructions

1.1 Using this manual

- ▶ Carefully read this operating manual before using the device for the first time.
- ▶ Also observe the operating manual enclosed with the accessories.
- ▶ The operating manual should be considered as part of the product and stored in a location that is easily accessible.
- ▶ When passing the device on to third parties, be sure to include this operating manual.
- ▶ If this manual is lost, please request another one. The current version can be found on our website <http://www.nbsc.com>.

1.2 Danger symbols and danger levels

1.2.1 Hazard symbols

	Hazard point		Burns
	Electric shock		Material damage
	Crush		

1.2.2 Degrees of danger

The following degree levels are used in safety messages throughout this manual. Acquaint yourself with each item and the potential risk if you disregard the safety message.

DANGER	<i>Will</i> lead to severe injuries or death.
WARNING	<i>May</i> lead to severe injuries or death.
CAUTION	May lead to light to moderate injuries.
NOTICE	May lead to material damage.

1.3 Symbols used

Example	Meaning
▶	You are requested to perform an action.
1. 2.	Perform these actions in the sequence described.
•	List.
	References useful information.

1.4 Abbreviations used

A	Amp
CFC	Chlorofluorocarbons
°C	Degree Celsius
HCFC	Hydrochlorofluorocarbon
HFC	Hydrofluorocarbon
Hz	Hertz
kg	Kilogram
lb	Pound
m	Meter
min	Minute
mm	Millimeter
N/A	Not applicable
rpm	Revolutions per Minute (min^{-1})
ULT	Ultra-Low Temperature
V	Volt

2 Safety

2.1 Intended use

New Brunswick Innova freezers are designed to provide precise, ultra-low temperature environments for cold storage of scientific or medical materials. They are designed to provide ultra-low temperature sample storage from -50 °C to -86 °C at 32 °C maximum ambient operating temperature.

2.2 Warnings for intended use

2.2.1 Manual conventions used



Risk of material damage

- ▶ This equipment must be operated as described in this manual.
- ▶ Please read the entire operating manual before attempting to use this equipment. If operational guidelines are not followed, equipment damage may occur.



Risk of personal injury

- ▶ Do not use this equipment in a hazardous atmosphere or with hazardous materials for which the equipment was not designed.
- ▶ Please read the entire operating manual before attempting to use this equipment. If operational guidelines are not followed, personal injury may occur.



Risk of personal injury

- ▶ Crush Warning messages alert you to specific procedures or practices regarding heavy objects which, if not followed correctly, could result in serious personal injury.



Risk of personal injury

- ▶ Flammable warning messages alert you to possible risks of of personal injury and equipment damage: protect the system from sparks and flames.

2.2.2 Health and safety at work act 1974

(FOR THE UNITED KINGDOM)

New Brunswick Scientific, as manufacturers and suppliers of laboratory equipment, are obliged under the terms of the above Act to provide our users with instructions on the safe installation, operation and maintenance of our equipment.

Our equipment is designed to acceptable standards and does not entail any hazard if used, as advised in the attached instructions.

The following safety precautions should be observed by all personnel using this equipment:

1. Read and understand this manual. If in doubt, contact your local New Brunswick sales office.
2. Do not remove any covers. There are no operable controls other than those referred to in this manual. There are voltages in excess of 41.5 volts AC behind the covers.
3. Use freezer gloves at all times when loading or unloading the equipment. The temperature of operation is such that direct contact with the cold contents or inside the equipment can burn unprotected skin.
4. Observe good housekeeping practices, at all times keeping the equipment and the adjacent areas clean, dry and uncluttered.
5. Should any malfunctions occur or be suspected, immediately call a qualified service engineer to investigate.

3 Product description

3.1 Main illustration

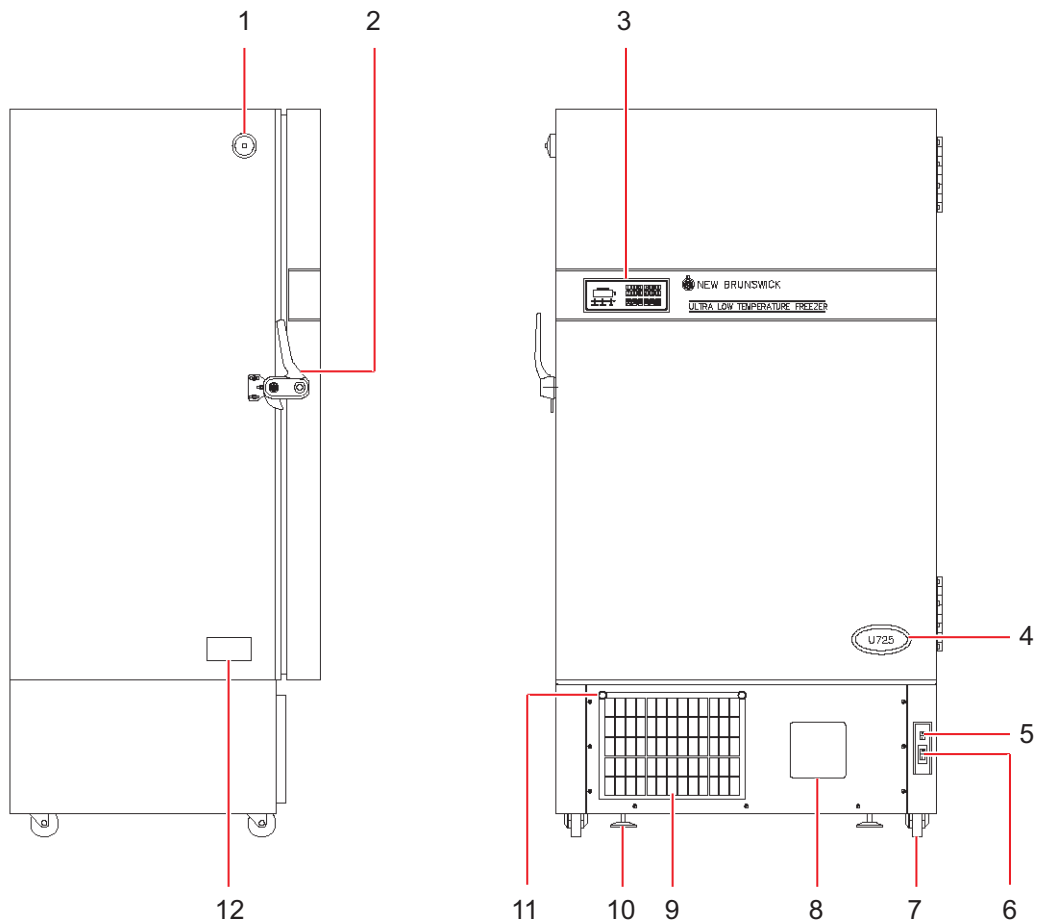

Fig. 1: Upright freezer - side and front views

1 Heated vent port	2 Door handle (lockable)
3 Control panel/display	4 Model label
5 Battery switch behind lockable panel	6 On/Off circuit breaker behind lockable panel
7 Transport castors	8 Chart recorder (optional)
9 Air filter grille	10 Adjustable feet
11 Quarter turn fastener	12 Specification plate

Innova® -86 °C Freezers – Operating manual

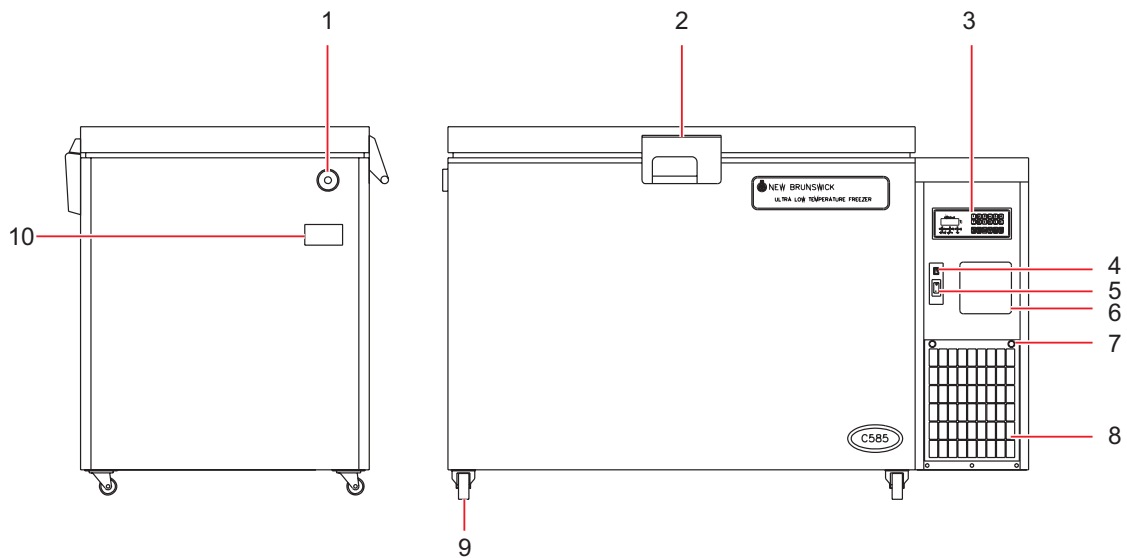

Fig. 2: Chest freezer - side and front views

1 Heated vent port	2 Lockable handle
3 Control panel/display	4 Battery switch (alarm) behind lockable panel
5 On/Off circuit breaker behind lockable panel	6 Chart recorder (optional)
7 Quarter turn fasteners	8 Air filter grille
9 Braked castors (front)	10 Specification plate

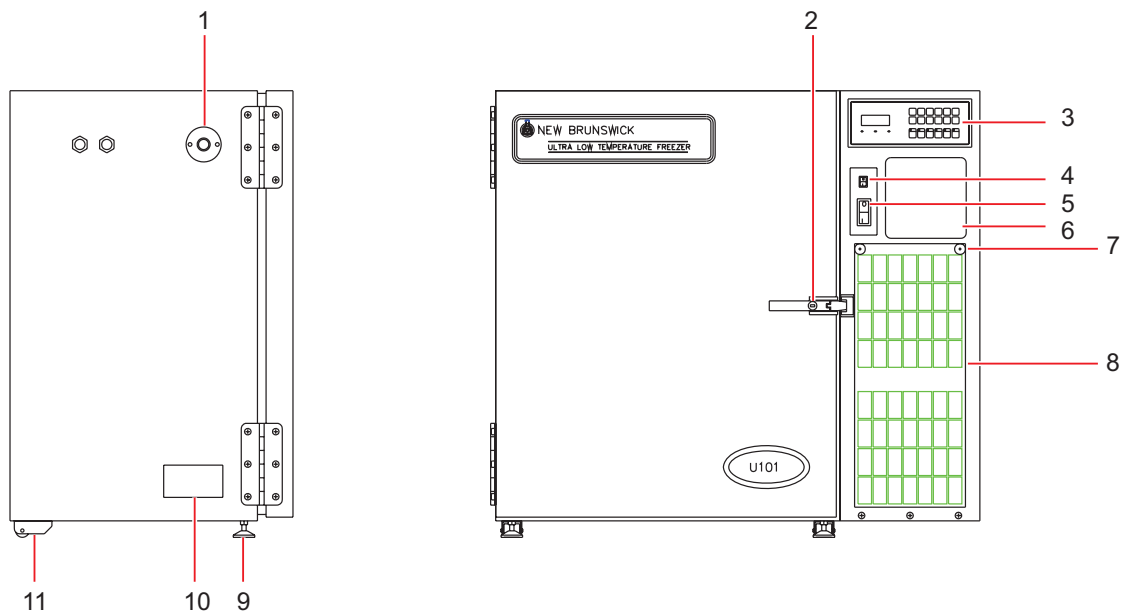

Fig. 3: U101 freezer - side and front views

1 Heated vent port	2 Lockable handle
3 Control panel/display	4 Battery switch (alarm) behind lockable panel
5 On/Off circuit breaker behind lockable panel	6 Chart recorder (optional)
7 Quarter turn fasteners	8 Air filter grille
9 Adjustable feet	10 Specification plate
11 Rear rollers	

3.2 Delivery package

3.2.1 Inspection of boxes

Inspect the boxes carefully for any damage that may have occurred during shipping. Report any damage to the carrier and to your local New Brunswick Sales Order Department immediately.

3.2.2 Packing list verification

Unpack your order, saving the packing materials for possible future use. Save the operating manual for instruction and reference. Verify against your New Brunswick packing list that you have received the correct materials, and that nothing is missing. If any part of your order was damaged during shipping, is missing, or fails to operate, fill out the "Customer Feedback" form, available online at www.nbsc.com/CustomerFeedback.aspx.



NOTICE!

Risk of material damage

- ▶ Vacuum insulation panels are used in the construction of these freezers. Inspect the cabinet panels for punctures or other damage that compromises the integrity of the product.
- ▶ These panels are mounted in the cavity against the steel outer wall of the freezer. Any drilling or puncture to the outer wall could release the vacuum from the panel, resulting in impaired freezer performance.
- ▶ Any unauthorized punctures or other damage deliberately made to the cabinet walls will invalidate the warranty.

3.3 Product versions

3.3.1 Introduction

This manual provides the user with the necessary information for installation and operation of New Brunswick's Innova® ultra-low temperature freezers with vacuum insulation panels. It also provides some preliminary user maintenance information.

This manual covers the following freezer models:

Model (230 V, 50 Hz)	Capacity
U101	101 liters (3.6 cubic feet)
U535	535 liters (18.9 cubic feet)
U725	725 liters (25.6 cubic feet)
C585	585 liters (20.7 cubic feet)
C760	760 liters (26.9 cubic feet)

Model (208 - 230 V, 60 Hz)	Capacity
U535	535 liters (18.9 cubic feet)
U725	725 liters (25.6 cubic feet)
C585	585 liters (20.7 cubic feet)
C760	760 liters (26.9 cubic feet)

Model (120 V, 60 Hz)	Capacity
U101	101 liters (3.6 cubic feet)
U535	535 liters (18.9 cubic feet)
C585	585 liters (20.7 cubic feet)

All freezers listed are totally free of CFCs (Chlorofluorocarbons) and HCFCs (Hydrochlorofluorocarbons). They use HFCs (Hydrofluorocarbons) as refrigerants.

3.4 Features

The freezers are manufactured using high quality steel and electronics for long life. The cabinets are insulated with a combination of foamed-in-place polyurethane foam and vacuum insulation panels. This combination ensures superior insulation properties while maintaining an extra large internal capacity for the footprint of the freezer. The Innova freezers have many features designed to provide ease of use and maintenance, security and reliability to your ultra-low temperature storage needs. They are built to stringent regulatory requirements for safety and environmental friendliness and disposability, and they are CE and UL certified.

Features include:

- Designed to be exceptionally energy efficient and eco-friendly.
- A setpoint keypad and digital temperature readout are provided on a control panel, located on the door of the upright freezers and on the console on the right side of chest freezers. Controls for setting the freezer temperature and alarm warning setpoints are enabled by an electronic lock. A unique code, which is selected by the user through the keypad, sets this lock. The code can be changed at any time, provided the current setting of the lock is known. **On delivery, the lock code is "0000" (unlocked).**
- Indicator lamps on the control panel provide warnings of power loss, system failure, exceeding High/Low temperature setpoints, low battery voltage, and filter blockage. There is also an LED to indicate when the freezer is under remote control via the RS-485 optional computer interface.
- Vacuum insulation panel technology reduces the cabinet wall thickness while maintaining superb insulation characteristics to provide the largest internal volume per floor space used.
- Freezers are totally free of CFCs (Chlorofluorocarbons) and HCFCs (Hydrochlorofluorocarbons). They use industrial grade, commercially available HFCs (Hydrofluorocarbons) as refrigerants.
- Upright models utilize gasketed and insulated inner doors to reduce cold air loss and recovery times, reduce internal temperature fluctuations and conserve energy. Chest models utilize insulated covers to reduce internal temperature fluctuations and conserve energy.
- Heavy-duty commercially available compressors provide rapid temperature pull-down and recovery after door opening.
- A heated port with ice-clearing plunger prevents vacuum formation enabling the outer door to be easily opened at anytime.
- All interior panels and shelves are made of high grade corrosion-resistant stainless steel, making them durable and easy to keep clean and sterilize.
- Inner doors lift off their hinges without the use of tools to simplify cleaning.
- Heavy duty castors enable easy installation and relocation (the model U101 has rear rollers and adjustable front legs.)
- Two access ports allow easy addition of sensors, or of back-up systems that can provide cooling protection for your samples in the case of a power outage or other system failure.
- An alarm contact is provided for connection to an external monitoring device or system.
- The freezers can be fitted with an optional 7-day circular chart recorder to provide independent temperature recording.
- An automatic reset restarts freezers at random 15 second intervals to protect the microprocessor controller from damage by electrical spikes caused by multiple freezers turning on at once.
- Lockable freezer handles on outer door provide added security against unauthorized users.
- An internal voltage stabilizer (60 Hz models only, except U101) that automatically compensates for variations in mains/power supply voltage (in case of over-voltage, brown-outs, dips, sags and surges).
- Multiple accessories are offered, including CO₂/LN₂ back-up systems, remote monitoring systems, external voltage stabilizer, inventory racking, and more.

3.5 Warranty

New Brunswick Scientific equipment is protected by a comprehensive warranty. The warranty covers faulty components and assembly, and our obligation under this warranty is limited to repairing or replacing the instrument or part thereof, which shall prove to be defective after our examination.

The warranty does not cover loss of time or materials, such as the loss of biological or biochemical by-products caused by any work interruption resulting from equipment failure; it does not extend to equipment that has been subject to misuse, neglect, accident or improper installation or application; nor does it cover any machine that has been repaired or altered by anyone other than an authorized factory-trained service representative, without prior written approval from your local New Brunswick sales office or distributor.

Expendable items such as bearings and seals, lamps, probes, sensors, glass, filters, single-use vessels, etc., are not covered.

The warranty begins on the date the equipment ships from New Brunswick Scientific or an authorized distributor and extends through the period indicated in the chart below:

Instrument		Parts Warranty	Labor Warranty
Freezers	ULT Freezers	5 years; vacuum insulation panels: 12 years	2 years
	Accessories ¹	1 year	1 year

¹ Chart recorders, CO₂/LN₂ back-up systems, etc.

3.5.1 Warranty registration

To register your warranty, complete the online form at www.nbsc.com under the **How Can We Help?** tab.

3.5.2 Extended warranty option

A variety of service plans are offered to help minimize downtime from unexpected malfunctions in equipment operation. Speak to your New Brunswick sales representative for more information.

4 Installation

4.1 Preparing installation



Risk of personal injury

- ▶ DO NOT attempt to lift any freezer by hand. Preferred lifting for loading and unloading is by mechanical lifting equipment.



Risk of material damage

- ▶ Maintenance, adjustment and repair work should be carried out only by QUALIFIED, EXPERIENCED personnel who have been AUTHORIZED to undertake such work by New Brunswick Scientific or its authorized agents.
- ▶ Failure to use authorized service agents will invalidate the warranty.

4.2 Selecting the location

All freezers are mounted on castors for ease of movement. The U101 upright freezer has two rear wheels. Upright freezers have feet that provide both a leveling feature and a locking feature to stop the freezer from rolling once it is in place. Chest freezers have locking front castors; these do not provide leveling adjustment, so the site chosen for the freezer must have a flat, level floor.

Position the freezer to allow disconnection to be made in respect to removal of the plug or appliance coupler, also the free air entry through the intake grille in the front and free air exit from the back. Provide a clearance of at least 150 mm (6 in) on all sides.

For efficient temperature control, the freezer should be placed in a shaded area, away from sources of excessive heat. For maximum cooling capability, the product should be located in an air-conditioned room.

4.3 Installing the shelves

Model U101 upright freezers are fitted with one fixed shelf. Model U535 and U725 upright freezers are fitted with two adjustable shelves. These can be positioned in 12.7 mm (½ in) steps anywhere throughout the freezer.

To effectively utilize racks within the freezer, be sure to position them so that each shelf is aligned with the bottom of each inner door.

Perform the following steps to install the shelves:

1. Ensure that the freezer is turned off and unplugged.
2. Remove the protective plastic coating from the shelf.
3. Position the four shelf clips evenly within the freezer by squeezing the clip, then inserting it into the shelf support within the freezer.
4. Place the shelf in the freezer, making sure all four shelf clips are supporting the weight of the shelf.

To readjust the shelf or shelf clips, gently squeeze the shelf clip to release it from the side of the freezer, then reposition it as needed.

4.4 Lockable freezer handle

Freezers are supplied with lockable handles.

The U101, C585, and C760 are fitted with quarter turn key locks.

The U535 and U725 upright freezer handle is fitted with barrel locks (push in and turn key to lock, turn key to unlock; the barrel will only lock when a key is turned to the lock position). The barrel lock may be removed from the upright freezer handle if the lock feature is not required.

An optional padlock adaptor can provide extra security by allowing the addition of a customer-supplied padlock to secure the freezer handle.

Removing the upright freezer handle barrel lock

Perform the following steps to remove the barrel lock from the upright freezer handle, if the lock feature is not required:

1. Open the freezer door and place the freezer handle in closed position.
2. Remove the two screws from behind the lock barrel.

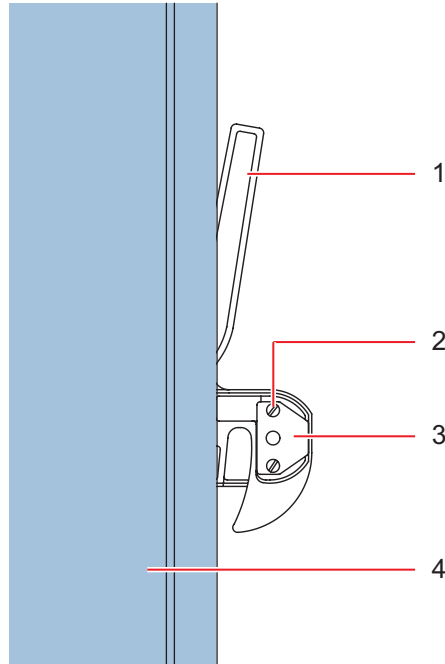

1 Freezer handle	2 Screw (1 of 2)
3 Lining plate	4 Freezer door wall

3. Remove the lining plate and lock barrel.
4. Insert the plastic blanking plug supplied.
5. Insert the lining plate and screw in the two screws.



It is important that the handle lock lining plate be installed at all times.



NOTICE!

Risk of material damage

- ▶ DO NOT SLAM THE DOOR WITH THE HANDLE IN THE CLOSED POSITION.

6. Place freezer handle in open position and close freezer door.

The door handle has a cam action to pull the door closed and a reverse cam action to break the seal so the door can be opened. When closing the outer door, ensure that the cam is engaged for correct operation. The initial vacuum inside the cabinet may cause the door to appear closed, but when the vacuum releases, the door will open. Always ensure the handle is properly engaged. It is important that the heated vent port is kept clear. This will avoid putting undue stress on the handle mechanism.

5 Operating controls and function

5.1 Controls and function

Operating controls are located on a control panel mounted in the door of the upright freezers, and on the console on the right side of chest freezers.

Every New Brunswick freezer is equipped with S.M.A.R.T. Plus™ diagnostic software, to help identify the cause of a fault or setpoint variance.

This section describes the controls and function of the control panel, (see Fig. 4 on p. 15).

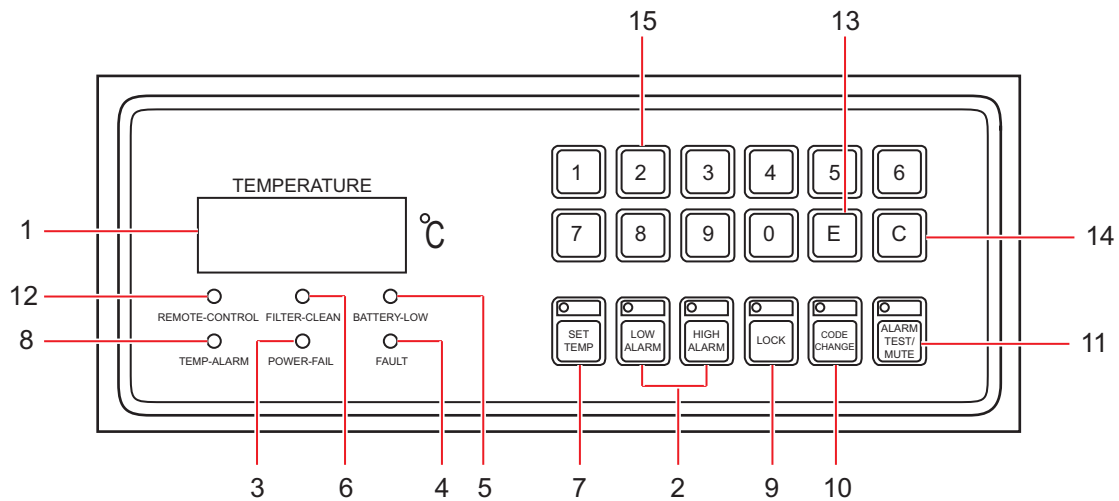

Fig. 4: Display panel & keypad

Temperature °C Display

Item	Name	Function
1	TEMPERATURE °C	The digital display normally shows the current internal temperature of the freezer. Temperature is displayed in 1 °C increments.

High alarm/low alarm

Item	Name	Function
2 & 8	[HIGH/LOW] TEMP-ALARM	The TEMP-ALARM illuminates and the audible alarm sounds if the freezer's internal temperature is above/below the user-selected alarm setpoints. The LED illuminates as soon as the setpoint is passed. The high temperature audible alarm has a programmable delay (see <i>Setting the alarm delay on p. 23</i>). After the temperature returns to the normal range, the TEMP-ALARM switches off and the audible warning stops.



The audible alarm can be silenced by pressing the **ALARM TEST/MUTE KEY**. If the temperature has not returned to normal range after the programmed time period, the audible warning will sound again. This pattern will continue to repeat until the temperature returns to normal.

Temp-alarm light

Item	Name	Function
8	TEMP-ALARM	Should a mains/power failure cause the temperature to surpass the alarm setpoint, the TEMP-ALARM illuminates. (The audible alarm will already be sounding due to the mains/power failure). The TEMP-ALARM lamp will extinguish when the temperature returns to normal set range. Cancel the TEMP-ALARM by pressing the ALARM TEST/MUTE KEY .

Power fail light

Item	Name	Function
3	POWER-FAIL	Illuminates if the mains/power supply fails, flashing at approximately 10-second intervals, accompanied by an audible alarm. When mains/power is restored, the indicator goes off and the audible alarm stops. (The battery must be switched on and charged for this indicator to operate.)

Fault light

Item	Name	Function
4	FAULT	Illuminates if there is a system failure within the freezer. Interfacing with the S.M.A.R.T. Plus™ diagnostics via the control panel, the fault can be determined (see <i>Error messages on p. 32</i>). System failure is accompanied by an audible alarm. Correction of the fault extinguishes the light and audible alarm.

Battery low light

Item	Name	Function
5	BATTERY-LOW	With mains/power ON : illuminates if battery voltage is below 6 volts, flashes when voltage drops to 5 Volts. With mains/power OFF : if battery voltage drop below 5.5 Volts, this fault indicator will stop functioning.

Filter clean light

Item	Name	Function
6	FILTER-CLEAN	Illuminates, accompanied by an audible alarm, to indicate a blocked or dirty filter. Filter is located on the front at the bottom of all freezers. Remove by turning the two thumbscrews on the filter holder ¼ turn. Clean filter by washing in mildly soapy water, then air dry. If filter warning light does not go out after replacing the cleaned filter, contact your local New Brunswick service representative.

Remote control light

Item	Name	Function
12	REMOTE CONTROL	Indicates when freezer is operating under remote computer control via the optional RS-485 interface port and New Brunswick's BioCommand® SFI software, or other laboratory data logging software.



The keypad controls are locked when the freezer is under remote control.

Set temp key

Operation in normal mode with **LOCK** lamp off.

Item	Name	Function
7	SET TEMP	Displays current temperature setting. Used to change temperature settings.

High alarm/low alarm keys

Operation in normal mode with **LOCK** lamp off.

Item	Name	Function
2	HIGH-ALARM	Displays current high alarm temperature setting.
2	LOW-ALARM	Displays current low alarm temperature setting.

Lock key

Operation in normal mode with **LOCK** lamp off.

Item	Name	Function
9	LOCK	Locks and unlocks the control panel for programming sequence.

Code change key

Operation in normal mode with **LOCK** lamp off.

Item	Name	Function
10	CODE CHANGE	Used to change freezer lock codes. Inactive in normal mode.

Alarm test/mute key

Operation in normal mode with **LOCK** lamp off.

Item	Name	Function
11	ALARM TEST/ MUTE	Sounds the audible alarm. If the audible alarm is on due to a fault condition, press this key to silence the alarm. The lamp LED lights can also be tested by pressing this key. The lights should all illuminate and the display should read "8888".



Using the **TEST/MUTE** button does NOT cancel remote alarm monitor socket switching.

"E" key

Operation in normal mode with **LOCK** lamp off.

Item	Name	Function
13	E	Used to enter data when programming.

"C" key

Operation in normal mode with **LOCK** lamp off.

Item	Name	Function
14	C	Used to cancel data when programming.

Numerical keys

Operation in normal mode with **LOCK** lamp off.

Item	Name	Function
15	NUMERICAL KEYS (1-0)	Used to input data when programming. Keys 8 and 9 are also used to program alarm delays (see <i>Setting the alarm delay on p. 23</i>).

6 Operation

6.1 Getting started



Risk of personal injury

- ▶ BEFORE connecting the freezer to the mains/electrical supply, make sure that the mains/power supply matches the requirements of the equipment. Check the specification plate (located on the side of the freezer) for the electrical requirements. The equipment should be connected to an earthed/grounded outlet socket.

6.1.1 Plug in

Once you have verified that the mains/power supply matches the electrical requirements of the freezer, connect the product to the mains/power supply using the mains/power cord provided.



Risk of personal injury

- ▶ If the freezer's voltage rating does not match your mains/electrical supply, or if the plug on the mains/power cord does not fit the outlet, do not plug the freezer in.
- ▶ Contact your laboratory supervisor, safety officer, or qualified service or electrical engineer.



Risk of material damage

- ▶ Some freezers are supplied with more than one removable mains/power cord. Utilize the cord that matches your power receptacle. Check the voltage rating plate on the side of the freezer, to confirm that the freezer is compatible with your laboratory mains/power supply.

6.1.2 Turning the freezer On/Off



Risk of personal injury

- ▶ The On/Off circuit breaker and battery switch are fitted with IP65 plastic covers, to prevent a possible source of ignition. These covers must not be removed. If one of the covers needs to be replaced, the replacement must be performed by a qualified and authorized person. Failure to observe this safety warning will invalidate the warranty and could result in a dangerous situation in the event of a failure.

The **ON/OFF** circuit breaker is located within the lockable panel at the bottom right-hand corner of the upright freezer or to the left of the control panel on the chest model.

To remove the lockable panel and turn the circuit breaker and battery switch On/Off:

1. Insert and turn the key (provided) one quarter turn to the right.



The key can be removed to prevent access.

2. Remove the panel.

- Set the **ON/OFF** circuit breaker and battery switch to the **I (ON)** position. The temperature display illuminates immediately.

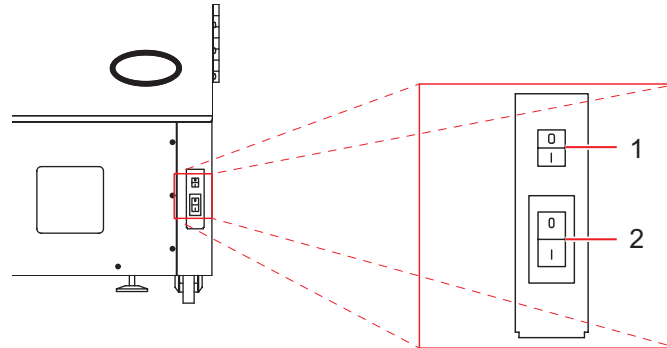

Fig. 5: Upright freezers switch location (except U101)

1 Battery switch	2 On/Off circuit breaker switch
-------------------------	--

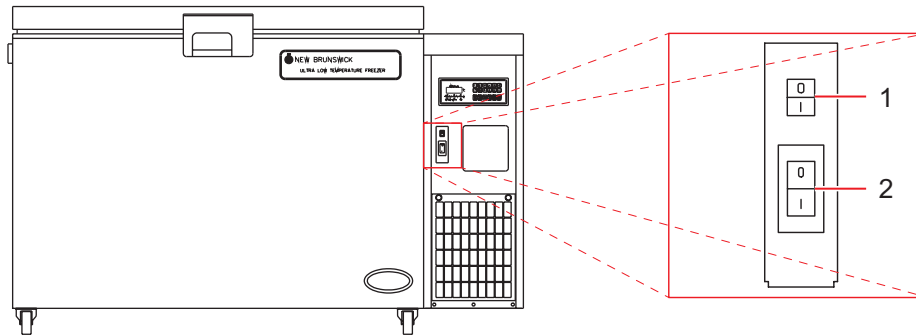

Fig. 6: Chest freezers (and U101) switch location

1 Battery switch	2 On/Off circuit breaker switch
-------------------------	--



The compressors will not operate for approximately three minutes after connection of the mains/power supply, because there is an automatic delay device in the circuit. Temperature and alarm settings can be adjusted immediately.

6.1.3 Alarm/battery activation

The equipment is delivered with the battery deactivated. The Power Fail alarm is activated by the battery rocker switch within the lockable panel, which is located at the bottom right-hand corner. The switch is labeled **I (ON)** and **O (OFF)**

!!Invalid cross reference to: 0

and

!!Invalid cross reference to: 0

- ▶ To activate the alarm, place the battery switch in the **I** position.



Failure to turn on the battery switch may lead to a discharged battery, low battery alarm indication, and/or a disabled alarm system.

- ▶ After activating the alarm, test its operation by pressing the **ALARM TEST/MUTE** key on the display. The audible alarm should sound.

The **ALARM TEST/MUTE** key also tests the LED lamps. All of the LEDs should light up together when the button is pressed.



Pull down time to -86 °C will be dependent on the freezer size and model (see *Specifications on p. 34*). The alarm will sound every 30 minutes until the temperature setpoint is reached. Use the **ALARM TEST/MUTE** key to mute the alarm during this initial pull-down period.

If the freezer is turned off during the initial pull-down period, the alarm will activate 30 minutes after switching it back on.

The factory-set temperature is -80°C.

6.1.4 Testing the alarm monitoring socket

The freezer is fitted with a remote alarm socket for testing power-fail and low battery alarms, and for connection to an external building monitoring system or optional auto-dialer, (see *Alarm monitoring socket on p. 25*). To test the alarm monitoring socket.

- ▶ Turn off (O) the **ON/OFF** circuit breaker.

This will test the **POWER FAIL** and **ALARM** output at the same time.

The battery must be switched on to test the **POWER FAIL**. The remote alarm facility provides voltage-free contacts rated at 1 amp, 24 volts maximum.

6.1.5 Vacuum Effect

After closing the freezer door following access to the contents, a vacuum may be created. Before the door can be opened again, it may be necessary to wait two or three minutes for the vacuum to be released by the vent port. **Do not try to force the door**. During the release of the vacuum, a slight hissing may be heard. In order to minimize vacuum formation, the vent heater assembly has a spring-loaded plunger to clear ice from the inside of the vent.



Be careful not to place a rack directly against the vent, as this will inhibit the plunger's ability to operate correctly (see *Heated vent port on p. 28*).

6.2 Programming the freezer

Set the freezer to any temperature within the range from -50 °C to -86 °C.



All temperature setpoints are automatically negative °C.

6.2.1 Setting operating temperature

To set the operating temperature for the freezer:

1. Press the **LOCK** key.



The **LOCK** lamp will flash if a lock code (password protection) is required, (see *Changing lock codes on p. 24*).

The **LOCK** lamp will illuminate, indicating the system is unlocked and parameters can be changed.

2. Press the **SET TEMP** key.
Its indicator will flash and the display will indicate 0.
3. Using the numerical keys, enter a new temperature (from -50 °C to -86 °C).
The temperature selected will appear in the **TEMPERATURE** display.
4. When the correct temperature is displayed, press the **E** key to enter the data. To set the high alarm setpoint skip to (see *Setting high alarm setpoint on p. 22*), step 2.
The **SET TEMP** lamp will go off.

5. Press the **LOCK** key to exit programming.
The **LOCK** lamp will go off and the freezer will return to normal mode.



Press the **C** key to clear the display during programming.

6.2.2 Setting high alarm setpoint

The high alarm setpoint may not be warmer than -10 °C and may not be less than within +5° of the operating temperature. The default setting is +5° from the temperature setpoint.

1. Press the **LOCK** key.



The **LOCK** lamp will flash if a lock code (password protection) is required, (see *Changing lock codes on p. 24*).

The **LOCK** lamp will illuminate, indicating the system is unlocked and parameters can be changed.

2. Press the **HIGH ALARM** key.
Its indicator will flash and the display will indicate 0.
3. Using the numerical keys, enter a new alarm setpoint temperature.
The selected temperature will appear in the **TEMPERATURE** display.
4. When the correct temperature is displayed, press the **E** (Enter) key to enter the data. To set the low alarm setpoint skip to (see *Setting low alarm setpoint on p. 22*), step 2.
The **HIGH ALARM** indicator will turn off.
5. Press the **LOCK** key to exit programming.
The **LOCK** lamp will go off and the freezer will return to normal mode.



Press the **C** key to clear the display during programming.

6.2.3 Setting low alarm setpoint

The low alarm setpoint may not be colder than -91 °C and may not be more than within -5° of the operating temperature. The default setting is -5 °C from the temperature setpoint.

1. Press the **LOCK** key.



The **LOCK** lamp will flash if a lock code (password protection) is required, (see *Changing lock codes on p. 24*).

The **LOCK** lamp will illuminate, indicating the system is unlocked and parameters can be changed.

2. Press the **LOW ALARM** key.
Its indicator will flash and the display will indicate 0.
3. Using the numerical keys, enter a new alarm setpoint temperature.
The selected temperature will appear in the **TEMPERATURE** display.
4. When the correct temperature is displayed, press the **E** (Enter) key to enter the data.
The **LOW ALARM** indicator will turn off.
5. Press the **LOCK** key to exit programming.
The **LOCK** lamp will go off and the freezer will return to normal mode.



Press the **C** key to clear the display during programming.

6.2.4 Checking temperature and alarm setpoint settings

To view the currently set operating temperature, high alarm setpoint, or low alarm setpoint for the freezer.

- ▶ Press the **SET TEMP** key, **HIGH ALARM** key, or the **LOW ALARM** key and read the display.



If you press the **SET TEMP**, **HIGH ALARM** or **LOW ALARM** key while the **LOCK** key lamp is flashing, the display will read ----, which indicates that the freezer is locked.

6.2.5 Setting the alarm delay

The **HIGH ALARM** audible alarm and the **REMOTE ALARM** monitoring socket can be programmed to a time delay set between 0 and 40 minutes.

The default time delay is 30 minutes. If the time delay is set to 0 minutes, the system will program it as 15 seconds.



Press **KEY 8** to display the High Temperature audible alarm delay, and press **KEY 9** to display the Remote Alarm Socket switching delay.

To set the audible **HIGH ALARM** delay (**KEY 8**):

1. Press the **LOCK** key.
The **LOCK** lamp illuminates, indicating the system is unlocked and parameters can be changed.
2. Press keypad button **8**.
pp flashes on the display.
3. Enter the desired value (e.g., press keypad buttons **1** and **0** to designate 10 minutes).
4. Press the **E** (Enter) key.
The **LOCK** lamp goes out.

To set the **REMOTE ALARM** socket time delay (**KEY 9**):

1. Press the **LOCK** key.
The **LOCK** lamp illuminate, indicating the system is unlocked and parameters can be changed.
2. Press keypad button **9**.
pp flashes on the display.
3. Enter the desired value (e.g., press keypad button **5** to designate 5 minutes).
4. Press the **E** (Enter) key.
The **LOCK** lamp goes out.

If the number entered is valid, --- flashes on the display, the value has been stored, and the **LOCK** lamp goes out. (This is a one-shot operation.)

If the number entered is out of range, **-EE-** shows on the display and the operation will need to be repeated using a valid number.

6.2.6 Changing lock codes



If you enter a lock code when there is none, or if you replace an existing lock code with a new one, take note of the new code before you enter it.

If the code is forgotten, you will need to contact Customer Service to regain access to the programming mode of the freezer.

The freezer is delivered unlocked. To change the code, the freezer must be unlocked. If a lock code has already been set (indicated by the **LOCK** lamp flashing when the **LOCK** key is pressed), that same code must be entered to unlock the freezer. When the freezer is unlocked, the **LOCK** lamp is on (not flashing).

Once the freezer is unlocked, follow these steps to set a new lock code:

1. Press the **CODE CHANGE** key.
The lamp will flash and the display will go blank.
2. Using the numerical keys, enter the new four-digit number. Check it on the display.
3. Press the **C** key to cancel the entry if the display shows it to be incorrect, then enter the correct number.
4. When the number is correct, record the new number somewhere secure. Then press the **E** (Enter) key.
The **CODE CHANGE** indicator will turn off.
5. Press the **LOCK** key.
Its indicator lamp will turn off.

The freezer now has a new lock code. If at any time you wish to change this code, you will have to enter this code to unlock the system before you can enter a new code.

Setting the lock code to **0000** disables the lock completely. With the **0000** code, you would need only press the **LOCK** key to reprogram the freezer.

6.2.7 Setting the temperature offset

The temperature offset function enables to add a temperature offset to the factory defined temperature settings.

1. Press the **LOCK** Key.
2. Press the **C** key to access the offset function.
3. Press **0**, **1**, **2**, **3**, or **4** key to set the offset in degrees.
4. Press the **ENTER** key to confirm selection.



Set temperature offset to "0" for no offset.

6.3 Battery backup switch

This is a rocker switch labeled **I/O** behind the locked front panel. In the **O** position, the battery is disconnected. This position should only be used while in transit, in storage, or to change the battery.

At all other times the switch should be kept in the **I** position for the battery to be charged, and for the alarm function to be available in the event of mains/power failure. **(Failure to set the switch may result in impaired battery life, and the alarm will not trigger if the mains/power fails.)**

With the battery switch on, during a mains/power failure, the internal freezer temperature will be displayed at ten-second intervals, and the audio alarm will also sound. The audible alarm may be muted by pressing the **ALARM TEST/MUTE** key on the control panel, but will sound again after 30 minutes if the fault has not been corrected. Pressing the same button again will mute the alarm for an additional 30 minutes; the pattern will continue to repeat until the initial problem is corrected.

6.4 Alarm monitoring socket

The freezers are provided with an alarm monitoring socket at the rear of the freezer and a matching plug for external monitoring. This plug can be connected either to a central monitoring system such as a building management system, or to a remote alarm via an auto-dialer.

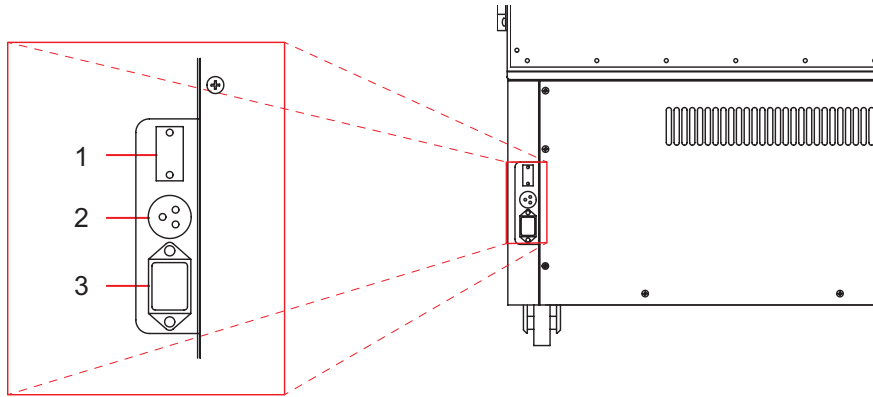

Fig. 7: Upright freezers alarm monitoring socket (except U101)

1 RS-485 connector (optional)	2 Alarm monitoring socket
3 Mains/power socket	

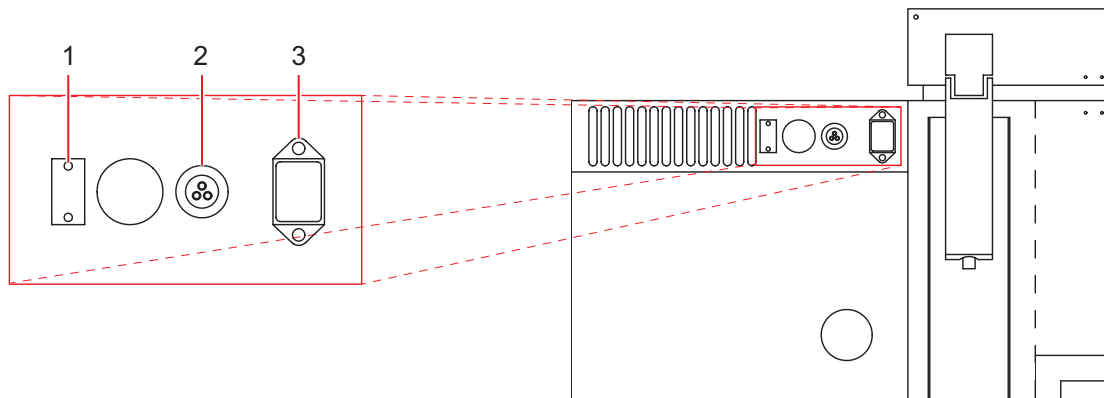

Fig. 8: Chest (and U101) freezers alarm monitoring socket

1 RS-485 connector (optional)	2 Alarm monitoring socket
3 Mains/power socket	

The configuration of the socket is shown in (Fig. 9 on p. 26) and (Fig. 10 on p. 26), as viewed from the rear of the freezer. Within the freezer, the socket is connected to voltage-free contacts rated at 24 volts, 1 amp. In normal operation, with the mains/power on, pin 1 is connected to pin 2 (N/C), and in the alarm condition, with mains/power off, pin 1 is connected to pin 3.

The High Temperature Alarm output to the Remote Alarm Monitoring Socket can be programmed to a set time delay (see *Setting the alarm delay on p. 23*).



NOTICE!

Risk of material damage

- ▶ Hazardous voltages must not be connected to the remote alarm socket. Max Rating 24 V 1 A.

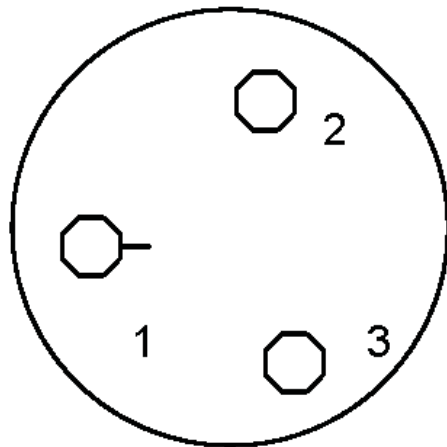

Fig. 9: Remote alarm socket - upright freezer (except U101)

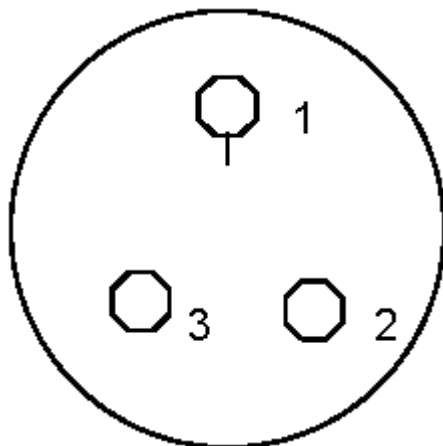

Fig. 10: Remote alarm socket - chest and U101 upright freezers

6.5 Voltage stabilizer

The following freezer models are equipped with a built-in voltage stabilizer:

- Innova U535, 120 V and 208 - 230 V, 60 Hz
- Innova U725, 208 - 230 V, 60 Hz
- Innova C585, 120 V and 208 - 230 V, 60 Hz
- Innova C760, 208 - 230 V, 60 Hz

The built-in voltage stabilizer automatically compensates for variations in the supply voltage (in case of over-voltage, brown-outs, dips, sags and surges). The output is only switched if the power disturbance is sustained for at least two seconds.

The U101 freezer has the option of an external voltage stabilizer.

The voltage stabilizer unit indication is displayed on the lower right front panel of the upright freezers and on the front panel above the air filter on the chest freezers.

When you switch the freezer on, if the input voltage is within the specified range, the green LED **NORMAL** will illuminate. If the voltage stays within the specified range, the green LED will remain illuminated.

Sustained variations in the input power will be automatically compensated for by the stabilizer circuit and indicated by a red LED for **HIGH** voltage or an amber LED for **LOW** voltage.

Tab. 1: Voltage stabilizer specifications

	208 - 230 V	120 V
Rated at	15 Amps	20 Amps
Line Voltage:		
• Normal Freezer Operating Voltage	230 V ± 10 %	120 V ± 10 %
• Normal Voltage Stabilizer Operating Range (LED Green)	204 V - 242 V ± 2.5 V	106 - 123 V ± 2.5 V
• Low (Boost) Voltage Limit (LED Amber)	< 204 V	< 106 V
• High (Buck) Voltage Limit (LED Red)	> 242 V	> 123 V

7 Maintenance

7.1 Cleaning



Risk of material damage

- ▶ Maintenance, adjustment and repair work should be carried out only by QUALIFIED, EXPERIENCED personnel who have been AUTHORIZED to undertake such work by New Brunswick Scientific or its authorized agents.
- ▶ Failure to use authorized service agents will invalidate the warranty.

7.1.1 Painted surfaces

All exterior paint work and inner doors should be cleaned using a solution of mild detergent in water. **Do not use abrasive cleaners or solvents.**

7.1.2 Panels and shelves

The interior panels and shelves are made of stainless steel. They may be cleaned and sterilized.

7.1.3 Air intake grille and filter



Risk of material damage

- ▶ Serious damage to the freezer may result if the air intake is blocked. Check that there is no obstruction of the airflow to the freezer. The air intake filter must also be cleaned regularly.
- ▶ Remove the filter from behind the grille by turning the thumbscrews $\frac{1}{4}$ turn and opening grille downward. The filter should be washed in warm soapy water and left to air dry before replacing.

The air intake grille must be cleaned regularly to keep it free from dust and debris. Under normal conditions, clean the grille once every three months. If the area around the freezer is very dusty or dirty, clean the grille more often.

- ▶ Brush the grille with a soft brush and, if a vacuum cleaner is available, vacuum the dust from the grille.

7.1.4 Heated vent port



There is an electrically-heated vent port in the freezer which must not be allowed to become blocked or sealed off.

Over a period of a few weeks, depending on how often the freezer is being used, a small mushroom of ice will form around the end of the vent port. If the vent port is allowed to become blocked, a vacuum will be created when the door is closed. It will not be possible to open the door or lift the lid until the vacuum has leaked away through the seal, which can take up to two hours due to the high quality of the seals.

The vent port is located on the left-hand side of the freezers.

- ▶ If the door cannot be opened, clear the vent port by pressing the manual plunger on the outside of the air vent.

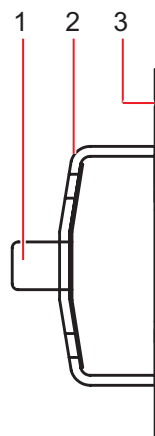

1 Plunger	2 Cover
3 Freezer outer wall	

7.1.5 Door or lid seal

Be sure to treat the door or lid seal with care. Avoid damaging this seal in any way. The freezer cannot operate properly with a defective seal.

- ▶ It is advisable to wipe both the seal and the surface against which it seals with a soft dry cloth once a month.

7.2 Routine maintenance

7.2.1 Lubrication

Every 12 months the outer door hinges and the handle mechanism should be *lightly* lubricated using general-purpose oil or spray grease.

7.2.2 Defrosting

After an extended period of operation, defrosting may become necessary:



NOTICE!

Risk of material damage

- ▶ Do not attempt to chip or scrape the ice with a sharp instrument. Allow the ice to melt naturally.

1. De-activate the alarm by switching the battery (alarm) switch (located behind the lockable panel on the front of the freezer) to off (O).
2. Unplug the freezer from the mains/electrical supply.
3. Leave the inner and outer doors or lids open.
4. Allow the accumulated ice to melt.
5. Mop up the resulting water.
6. Dry and decontaminate the interior of the freezer.
7. When defrosting is complete, reconnect the freezer to the mains/electrical supply.
8. Turn the mains/power switch on (I) and re-activate the battery (alarm) switch.

7.2.3 Removing the inner doors

The inner doors of the freezer can be removed for defrosting and cleaning.

1. Fully open the outer door of the freezer.
2. Fully open the inner door.

3. Lift off inner door from hinges and set aside.

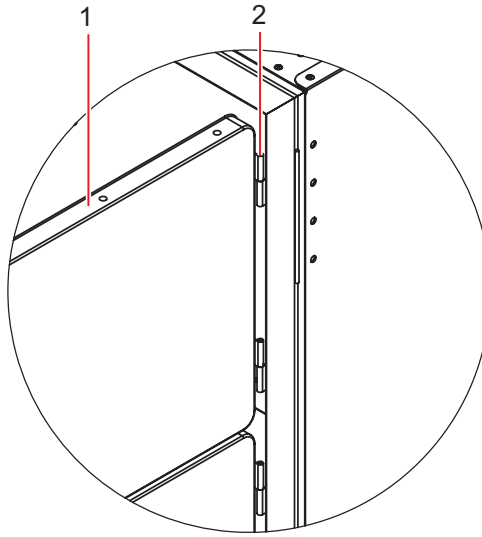

Fig. 11: Lift-off inner door

1 Inner door	2 Lift-off hinge
---------------------	-------------------------

Repeat procedure for each door.

7.2.4 Replacing the inner door

1. Fully open the outer door of the freezer.
2. Fit door to hinge pins and close.
3. Check to ensure that inner door gasket is sealing against the freezer trim.
4. If required, adjust the latch retainer by loosening the screws and moving forward or backwards.
5. Close outer door.

7.2.5 Electrical components



Risk of personal injury

- ▶ During routine maintenance, care must be taken to avoid any damage to the gaskets and sealing grommets of these enclosures; also check the gaskets and sealing grommets routinely to ensure their integrity. Should any damage or deformity be detected, the gasket and/or sealing grommet must be replaced immediately.
- ▶ Failure to observe this safety warning will invalidate the warranty and could result in a dangerous situation.

Lamps

Regularly check the indicator lamps:

- ▶ Press the **ALARM TEST/MUTE** key.
All of the indicator lamps should illuminate, and the display should read **8888**.

Alarms

Regularly check the alarm:

- ▶ Press the **ALARM TEST/MUTE** key.
The **TEMP** indicator should illuminate and the audible alarm should sound.

Battery replacement



Risk of material damage

- ▶ There are no user controls behind any panels. The removal of any other part or panels from the freezer by anyone other than a qualified, authorized Service Engineer may invalidate the warranty.



Risk of material damage

- ▶ Use only a replacement battery of the correct type and part number.
- ▶ The battery must be fitted so the terminals correspond to the polarity labels on the electrical panel.

The YUASA–NP6 V 2.8 Ah battery is mounted on the electrical panel. This is located behind the right-hand base cover.

To replace the battery:

1. Switch off the mains/power switch and disconnect the mains/power supply.
2. Remove the side cover and the battery clamp securing the battery to the electrical panel.
3. Disconnect the battery terminals.
4. Install the new battery, fixing screws, and the side cover.



Be certain, when reconnecting the battery, to respect the correct polarity (red is + positive and black is – negative).

5. Reconnect the freezer to the mains/power supply and turn the mains/power switch on (I).

Fuses

Fuses must be replaced by a New Brunswick Scientific approved service engineer. Contact New Brunswick Service.

8 Troubleshooting

8.1 General errors

If you are experiencing a problem with your freezer, check the following troubleshooting guides before contacting your New Brunswick authorized Service technician.

Symptom/ message	Cause	Remedy
Door will not open	<ol style="list-style-type: none"> The door handle is locked. The heated vent port is blocked. 	<ol style="list-style-type: none"> Unlock the door handle. Break up the ice in the vent port using the plunger, (see <i>Heated vent port on p. 28</i>). <p>If the door will not open:</p> <ul style="list-style-type: none"> ▶ Call New Brunswick Service.
FILTER-CLEAN LED lights up	<ul style="list-style-type: none"> Filter is contaminated. 	<ul style="list-style-type: none"> ▶ Clean the filter, (see <i>Air intake grille and filter on p. 28</i>). <p>If the LED remains lit:</p> <ul style="list-style-type: none"> ▶ Call New Brunswick Service.

8.2 Error messages

Your electronically-controlled New Brunswick freezer incorporates the unique Systems Monitoring And Reporting Technology (S.M.A.R.T. Plus™) self-diagnostic software to diagnose faults in its electronic systems, its probes and/or its refrigeration system.

This table interprets error codes that may appear in the control panel display:

Symptom/ message	Cause	Remedy
E-01	<ul style="list-style-type: none"> PT100 Probe 1 failure. This probe, located inside the freezer cabinet, indicates cabinet temperature. 	<ul style="list-style-type: none"> ▶ Call New Brunswick Service department.
E-02	<ul style="list-style-type: none"> Probe 2 failure. This probe monitors the cascade condenser. 	<ul style="list-style-type: none"> ▶ Call New Brunswick Service department.
E-03	<ul style="list-style-type: none"> This probe monitors the air-cooled condenser. 	<ul style="list-style-type: none"> ▶ Call New Brunswick Service department.
E-04	<p>Air-cooled condenser temperature too high:</p> <ol style="list-style-type: none"> Filter may be blocked. Ambient temperature may be too high. <p>If alarm continues to sound:</p> <ul style="list-style-type: none"> Fan may have failed. Water supply not turned on, insufficient flow, regulating valve not opening or defective (water-cooled version only). 	<ol style="list-style-type: none"> Clean filter according to the instructions (see <i>Air intake grille and filter on p. 28</i>). Cool the room. <ul style="list-style-type: none"> ▶ Call New Brunswick Service department.



A fan is required to cool the compressors on the water-cooled models.

8.3 After a mains/power failure

If mains/power is interrupted, the **POWER-FAIL** indicator lamp (see Fig. 4 on p. 15), Item 3, will illuminate. In addition, the audible alarm will sound and the display will flash at approximately 10-second intervals.

When mains/power is restored, both alarm and light will automatically be cancelled.

If mains/power has been interrupted for only a short time, the internal temperature of the freezer will not have risen above the temperature setpoint (the user-set alarm threshold), so normal operation will be resumed immediately.

If the interruption was long enough for the internal temperature to rise above the temperature setpoint, the **TEMP-ALARM** indicator will illuminate. If the internal temperature does not fall below the temperature setpoint within the programmed time after mains/power was restored, the audible alarm will sound again. The TEMP-ALARM indicator will extinguish when the internal temperature reaches the High Alarm temperature set point.

8.4 Interior warming

If the lid or door is left open long enough for the internal temperature to rise above the temperature setpoint, the same effects will be observed as described above regarding power failure.

To minimize the risk of this happening, the lid or door should only be opened when necessary, for a short period of time.

The upright freezers are fitted with internal doors which latch shut, minimizing temperature rise when the outer door is opened. Chest freezers are fitted with inner insulating lids to ensure efficient running of the freezer. The lids should remain fitted at all times when the freezer is running.

Innova® -86 °C Freezers – Operating manual

9 Technical data

9.1 Specifications

9.1.1 Upright freezers specifications

Model No.	U101	U535	U725
Part No.	U9420-000X*	U9430-000X*	U9440-000X*
Internal Dimensions: Height x Width x Depth	640 x 480 x 330 mm 25.2 x 18.9 x 13 in	1365 x 640 x 615 mm 53.7 x 25.2 x 24.2 in	1365 x 865 x 615 mm 53.7 x 34.0 x 24.2 in
External Dimensions: Height x Width x Depth	830 x 900 x 566 mm 32.7 x 35.4 x 22.3 in	1950 x 800 x 867 mm 76.8 x 31.5 x 34.1 in	1950 x 1025 x 867 mm 76.8 x 40.4 x 34.1 in
Capacity	101 Liters 3.6 cubic feet	535 Liters 18.9 cubic feet	725 Liters 25.6 cubic feet
Net Weight	116 kg 256 lb	250 kg 551 lb	315 kg 693 lb
Lock	Standard	Standard	Standard
No. Compartments	2	3	3
Interior	Stainless steel grade 304L		
Alarms	High/Low temperature, power fail, battery low, filter clean, fault		
Insulation Material	Vacuum insulation panels and urethane foam		
Remote alarm port	Standard	Standard	Standard
RS-485 interface	Optional	Optional	Optional
Refrigerants:	High Stage Refrigerant: R404A / Low Stage Refrigerant: R508B		
‡Power Consumption:			
• 120 V electrical supply	265 Watts	550 Watts	N/A
• 208 - 230 V electrical supply	N/A	550 Watts	685 Watts
• 230 V electrical supply	367 Watts	550 Watts	660 Watts
Mains/Power Source and Current Rating:			
120 V, 60 Hz	13 A	16.5 A	N/A
208 - 230 V, 60 Hz	N/A	9 A	10 A
230 V, 50 Hz	5 A	5 A	9.5 A
Pull Down Time: From +25 °C to -85 °C (freezer empty; 240 V, 50 Hz electrical supply)			
	3.7 hours	5.3 hours	5.6 hours
Performance	-50 °C to -86 °C at 32 °C maximum ambient operating temperature		
Environmental Conditions	All freezers use components tested to CE/UL specifications listed below: <ul style="list-style-type: none"> • Indoor use • Altitude up to 2000 m • Ambient temperature range 10 °C to 32 °C • Maximum relative humidity 80 % for temperatures up to 31 °C, decreasing linearly to 50 % relative humidity at 40 °C • Mains/power supply voltage fluctuations not to exceed ± 10 % of the nominal voltage • Installation category II • Pollution degree 2 		

* X = 0 for 120 V, 2 for 208 - 230 V (N/A for U101), or 1 for 230 V

‡ Freezer set to -80 °C, ambient 20 - 25 °C at rated mains/electrical supply

Innova® -86 °C Freezers – Operating manual

9.1.2 Chest freezers specifications

Model No.	C585	C760
Part No.	U9400-000X*	U9410-000X*
Internal Dimensions: Height x Width x Depth	780 x 1200 x 625 mm 30.7 x 47.2 x 24.6 in	780 x 1560 x 625 mm 30.7 x 61.4 x 24.6 in
External Dimensions: Height x Width x Depth	1092 x 1690 x 785 mm 43 x 66.5 x 30.9 in	1092 x 2050 x 785 mm 43 x 80.7 x 30.9 in
Capacity	585 Liters 20.7 cubic feet	760 Liters 26.9 cubic feet
Net Weight	240 kg 528 lb	285 kg 627 lb
Lock	Standard	Standard
No. Compartments	N/A	N/A
Interior	Stainless steel grade 304L	
Alarms	High/Low temperature, power fail, battery low, filter clean, fault.	
Insulation Material	Vacuum insulation panels and urethane foam	
Remote alarm port	Standard	Standard
RS-485 interface	Optional	Optional
Refrigerants:	High Stage Refrigerant: R404A / Low Stage Refrigerant: R508B	
‡Power Consumption:		
• 120 V electrical supply	580 Watts	N/A
• 208 - 230 V electrical supply	580 Watts	698 Watts
• 230 V electrical supply	565 Watts	665 Watts
Mains/Power Source and Current Rating:		
120 V, 60 Hz	16.5 A	N/A
208 - 230 V, 60 Hz	9 A	10 A
230 V, 50 Hz	5.5 A	9.5 A
Pull Down Time: From +25 °C to -85 °C (freezer empty; 230 V, 50 Hz electrical supply)		
	4.5 hours	5.8 hours
Performance	-50 °C to -86 °C at 32 °C maximum ambient operating temperature	
Environmental Conditions	All freezers use components tested to CE/UL specifications listed below: <ul style="list-style-type: none"> • Indoor use • Altitude up to 2000 m • Ambient temperature range 10 °C to 32 °C • Maximum relative humidity 80 % for temperatures up to 31 °C, decreasing linearly to 50 % relative humidity at 40 °C • Mains/power supply voltage fluctuations not to exceed ± 10 % of the nominal voltage • Installation category II • Pollution degree 2 	

* X = 0 for 120 V, 2 for 208 - 230 V, or 1 for 230 V

‡ Freezer set to -80 °C, ambient 20 - 25 °C at rated mains/electrical supply

10 Ordering Information

10.1 Accessories

A number of accessories are available for New Brunswick's range of ultra-low temperature freezers. Contact your local New Brunswick representative or distributor for details.

10.1.1 A2 independent temperature monitor

The A2 system is an independent temperature monitor with alarm, electronic chart recorder, and auto-dialer that communicates via the internet for remote monitoring from anywhere in the world. Ask your New Brunswick sales representative for availability.

10.1.2 Auto-dialers

Auto-dialers can call a set of preprogrammed telephone numbers in the event of an alarm condition and connect right into the freezer's remote alarm port.

10.1.3 Temperature probes

Additional Temperature Probes (such as the New Brunswick A2 monitoring system) can be installed upon request for an external alarm system or for validation.

10.1.4 Validation packages

Installation and operational qualifications are available.

10.1.5 External voltage stabilizers

External voltage stabilizers are available for 50 Hz and 60 Hz Innova U101 models to modulate incoming line voltage.

10.1.6 Padlock adapter kits

Padlock adapter kits allow up to two user-supplied padlocks to be secured to outer door handle for extra security.

10.1.7 CO₂ and LN₂ back-up systems

These systems are available to temporarily protect the contents of the freezer against the consequences of freezer failure or power failure. In an emergency, the system can inject either liquid carbon dioxide or liquid nitrogen from a storage bottle. Carbon dioxide back-up systems will maintain temperatures between -40 °C and -70 °C (subject to environmental conditions) for a period of up to 48 hours, during which time the freezer can be repaired. Liquid nitrogen back-up systems will maintain the freezer temperature at -86 °C.

CO₂ and LN₂ back up systems can be retrofitted by the user. Contact your local New Brunswick distributor for options available. Instructions are included in the kit.

10.1.8 Inventory racking systems

A very comprehensive set of anodized aluminium racks is available. These are designed to accommodate various sizes of boxes neatly, while giving maximum packing density in the freezer. Stainless-steel shelves and water proof boxes as well as custom racking are also available.

10.1.9 Chart recorder

A chart recorder is available to provide a continuous record of the temperature inside the freezer over a period of seven days. The record is presented on a circular chart.

The following items are available for all freezer models:

Order No. (International)	Description	Quantity
K0440-0355	Chart Recorder Kit	1
K0540-0025	Chart Recorder Paper	100
K0660-0051	Chart Recorder Pens	3

10.1.10 New Brunswick BioCommand SFI datalogging software (RS-485 interface)

New Brunswick Scientific's BioCommand® SFI Track and Trend software is available to trend and archive data from as many as 32 shakers, CO₂ incubators, and/or freezers, simultaneously. This PC-based software works with any OPC-compliant equipment with an RS-232 or RS-485 port.

11 Transport, storage and disposal

11.1 Shut down

- ▶ Switch the battery switch off before transporting or storing the equipment, (see *Battery backup switch* on p. 24).

11.2 Transport



Risk of personal injury

Lifting and transporting the freezer without suitable equipments can result in crushing and other injuries.

- ▶ Use a mechanical lifting equipment to load and unload the freezer.



Risk of material damage

Vibrations and impacts can cause the hermetically sealed compressors to slip out of their suspension system.

- ▶ Do not tilt the equipment.
- ▶ Avoid vibrations and impacts.

Perform the following steps if relocation is necessary:

1. Remove all shelves, racks, and boxes.
2. Carefully move the freezer.

11.3 Disposal

In case the product is to be disposed of, the relevant legal regulations are to be observed.

Information on the disposal of electrical and electronic devices in the European Community:

Within the European Community, the disposal of electrical devices is regulated by national regulations based on EU Directive 2002/96/EC pertaining to waste electrical and electronic equipment (WEEE).

According to these regulations, any devices supplied after August 13, 2005, in the business-to-business sphere, to which this product is assigned, may no longer be disposed of in municipal or domestic waste. To document this, they have been marked with the following identification:



Because disposal regulations may differ from one country to another within the EU, please contact your supplier if necessary.

In Germany, this is mandatory from March 23, 2006. From this date, the manufacturer has to offer a suitable method of return for all devices supplied after August 13, 2005. For all devices supplied before August 13, 2005, the last user is responsible for the correct disposal.



DECLARATION OF CONFORMITY

New Brunswick Scientific declares that the Ultra Low Temperature Freezers products listed conform to the European Union Directives and Standards identified in the declaration.

- Innova U101
- Innova U360*
- Innova U535 Premium U410
- Innova U725 Premium U570
- Innova C585 Premium C340
- Innova C760 Premium C660

CE Marked Complies with EC directive 93/68/EEC

Electromagnetic Compatibility (EMC) 89/336/EEC & Amendment 92/31/EEC

- Test Standard BS EN 55014-1 : 1997
- Test Standard BS EN 55014-2 : 1997
- Test Standard BS EN 61000-3-2 : 1995
- Test Standard BS EN 61000-3-3 : 1995

*Test Standard EMC EN61326 : 1997 A1, A2 (U360 only)

Low Voltage Directive (LVD) 73/23/EEC

- Test Standard EN 61010-1 : 1993 Amendment A2 : 1995
- Test Standard ISO 5149 : 1993 (E)

UL 61010A-1 CSA C22.2 No. 1010.1 UL File E234047 (U.S. Voltage Models)

Conducted/Radiated Emissions FCC Part 15 Class B (U.S. Voltage Models)

Approved by _____ on this 26th day of August, 2011
M. King. Managing Director UK Operations

New Brunswick Scientific Co., Inc., 44 Talmadge Road, Edison, NJ 08818, USA
New Brunswick Scientific (UK) Ltd, 17 Alban Park, St. Albans, AL4 0JJ, UK
New Brunswick Scientific BV, Kerkenbos 1101, Nijmegen 6546 BC, NL

Index

A

Accessories	36
Adjusting the shelf	13
Air intake	28
Alarm	24
Alarm activation	20
Alarm test/mute key	24
Audible alarm	15, 24
Auto-dialers.....	36
Auto-reset	11
Automatic reset.....	11

B

Battery activation	20
Battery backup switch.....	24
Battery replacement.....	31

C

C760 Specifications	35
Caution, explanation of	5
CFC	6
Chart recorder.....	36
Chest freezer, side and front views.....	8
Cleaning.....	28, 29
Clearance	13
CO2 back-up system.....	36
Control panel	15
Copyright	2
Custom-made racks.....	36

D

Danger, explanation of	5
Defrosting	29
Disposal	38
Door seal	29
Door/lid stuck.....	21

E

Electrical connection.....	19
Electrical requirements	19
Error codes	32
Extended warranty option	12
External monitoring.....	25
External voltage stabilizer	36

F

Factory-set temperature.....	21
Fail, mains/power	33

H

Hazard symbols.....	5
HCFC.....	6
HFC	6

I

Ice in vent	21, 28
Indicator lights	11
Inner door, installing	30
Inner door, removing.....	29
Inspection of boxes.....	10
Installing inner door	30
Intended use.....	7

L

Lid/door stuck	21
LN2 back-up system	36
Lock key	21
Lockable panel	20

M

Mains/power cord	19
Mains/power failure.....	33
Mains/power supply	19
Manual conventions.....	5
min.....	6
Monitoring	25, 37
Moving freezer	38

N

Notice, explanation of	5
------------------------------	---

P

Packing list verification	10
Panel, removing.....	19
Part numbers	36
Plunger	21, 28
Power fail	21
Power failure.....	24
Power supply/mains.....	19
Programming	21

R

Racks.....	36
Recorder pens	36
Recorder, chart.....	36
Registration, warranty.....	12
Remote control	8
Remote monitoring	25, 37
Removing inner doors	29
Removing lockable panel	19

Removing upright freezer lock barrel	14
Rise in temperature.....	33
rpm.....	6
RS-485 computer interface.....	37

S

S.M.A.R.T. Plus.....	15, 32
Safety.....	7
Set temp key	21
Setpoint, temperature	33
Setting the operating temperature	21
Shelf, adjusting	13
Specifications, C585	35
Specifications, U101	34
Specifications, voltage stabilizer	27
Symbols used	5

T

Temp alarm	33
Temperature alarms.....	15
Temperature probes.....	36
Temperature setpoint	21, 33
Testing alarm	30
Testing alarm monitoring socket	21
Testing indicator lamps	30
Trademarks.....	2
Troubleshooting	32
Turning on the equipment	19

U

U535 Specifications	34
U725 Specifications	34
Unpacking boxes	10
Upright freezer, front view	8
Upright freezer, side and front views	8
Using this manual	5

V

Vacuum effect	21
Validation packages.....	36
Vent.....	21, 28
Voltage stabilizer.....	26, 26
Voltage stabilizer operation.....	26
Voltage stabilizer specifications	27
Voltage stabilizer, description	26

W

Warming.....	33
Warning, explanation of	5
Warranty	12
Warranty, extended	12





Evaluate your operating manual

www.eppendorf.com/manualfeedback

eppendorf
In touch with life

New Brunswick Scientific • www.nbsc.com • bioinfo@nbsc.com • For your local sales office or distributor contact:
Eppendorf AG · 22331 Hamburg · Germany · Tel: +49 40 538 01-0 · Fax: +49 40 538 01-556 · E-mail: eppendorf@eppendorf.com
New Brunswick Scientific Europe B.V. · Nijmegen · The Netherlands · Tel: +31 (0) 24 3717 600 · Email: europe@nbsbv.nl
Eppendorf North America, Inc. · Hauppauge, N.Y. USA · Tel: +1 516 334 7500 · +1 800 645 3050 · E-mail: info@eppendorf.com

Application Support Europe, International: Tel: +49 1803 666 789 · E-mail: support@eppendorf.com
North America: Tel: +1 800 645 3050 menu option 2 · E-mail: techserv@eppendorf.com
Asia Pacific: Tel: +603 8023 6869 · E-mail: support_asiapacific@eppendorf.com